

# UCG 100 - 12

12V 100AH

AGM GEL

# Ultracell®

'Quality in Every Language'

Image



Terminal Type

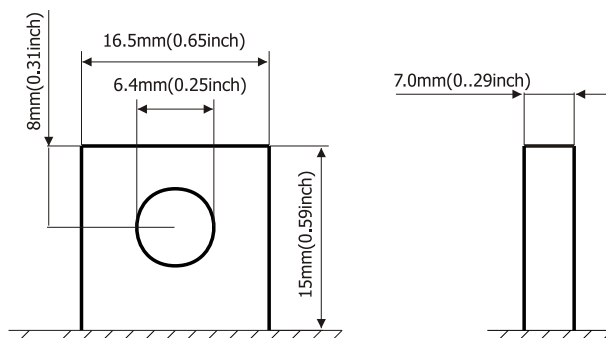

Dimensions

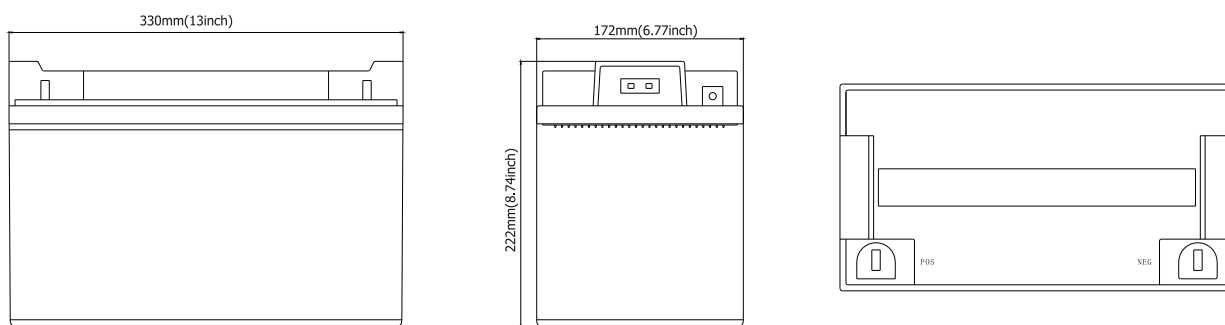

Specifications

Battery Model	UCG 100 - 12			
Designed Floating Life	15 Years			
Capacity (25°C)	20HR (5.15A, 1.75V)	10HR (10A, 1.75V)	5HR (16.5A, 1.75V)	1HR (62A, 1.75V)
	103AH	100AH	82.5AH	62AH
Dimensions	Length	Width	Height	Total Height
	330mm	172mm	222mm	222mm
Approx. Weight	31.6Kg			
Internal Resistance	Fully Charged at 25°C 0.005 Ohm			
Self Discharge	3% of capacity declined per month at 25°C			
Capacity Affected by Temperature	40°C	25°C	0°C	-15°C
	102%	100%	85%	65%
Charge Voltage (25°C)	Cycle Use		Float Use	
	14.4-15V (-30mV/C), max. Current: 25A		13.6-13.8V (-20mV/C)	

Construction

Component ——— Raw material  
 Positive ——— Lead dioxide  
 Negative ——— Lead  
 Container ——— ABS (Flame Retardent optional)  
 Cover ——— ABS (Flame Retardent optional)

*Sealed and maintenance free option*

Sealant ——— Epoxy Resin  
 Safety Valve ——— EPDR  
 Terminal ——— Copper  
 Separator ——— Fibre Glass  
 Electrolyte ——— Sulphuric acid and Gel

*Non-spillable construction design*



CE 1188



MH 29410

Tel | +44 (0) 151 523 2777  
 Fax | +44 (0) 151 523 0855  
 E-mail | info@ultracell.co.uk  
 Web | www.ultracell.co.uk

### Charge Characteristic

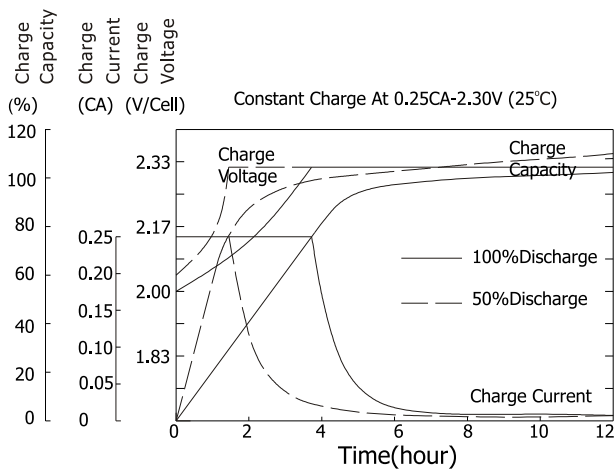

### Discharge Characteristic 25°C

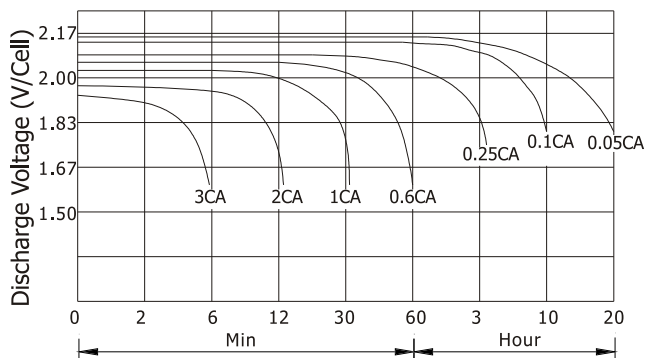

### Relationship of OCV and state of charge

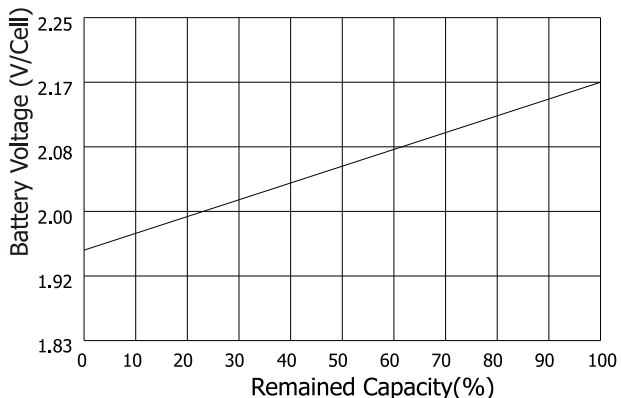

### Life Expectancy Cycle Use:

- 100% depth of discharge 350 cycles
- 80% depth of discharge 600 cycles
- 50% depth of discharge 900 cycles
- 30% depth of discharge 1500 cycles
- 20% depth of discharge 1700 cycles

### Constant Current Discharge Ratings - amperes at 25°C

F.V / Time	5 MIN	10 MIN	15 MIN	30 MIN	1 HR	3 HR	5 HR	10 HR	20 HR
1.60 V	350	240	175	105	66.0	27.3	13.2	10.6	5.27
1.67 V	315	219	170	102	65.9	27.2	13.0	10.4	5.25
1.70 V	299	211	164	100	65.7	27.2	12.9	10.4	5.25
1.75 V	266	195	155	98.0	65.0	27.0	12.7	10.2	5.23
1.80 V	240	181	148	95.0	64.2	26.9	12.4	10.0	5.04
1.85 V	182	149	128	87.4	63.5	26.8	12.2	9.83	4.94

### Constant Power Discharge Ratings - watts at 25°C

F.V / Time	5 MIN	10 MIN	15 MIN	30 MIN	1 HR	3 HR	5 HR	10 HR	20 HR
1.60 V	577	398	310	198	130	52.4	26.6	21.4	10.5
1.67 V	547	393	307	194	126	52.4	26.2	21.1	10.5
1.70 V	511	383	302	189	122	52.4	26.0	20.9	10.5
1.75 V	476	358	284	184	121	51.6	25.6	20.6	10.5
1.80 V	427	333	267	179	119	50.9	25.1	20.2	10.1
1.85 V	342	276	233	164	118	50.7	24.7	19.9	9.87



CE 1188



MH 29410

**Tel** | +44 (0) 151 523 2777  
**Fax** | +44 (0) 151 523 0855  
**E-mail** | info@ultracell.co.uk  
**Web** | www.ultracell.co.uk